

## Optimization of Ball Diameter

### Application:

HONDA Civic VIII

**GSP Part Number:** S080075, S080076

### Problem

British customers reported that the ball joint was unstable in operation and vibrated during steering, which affected the service life of the product.

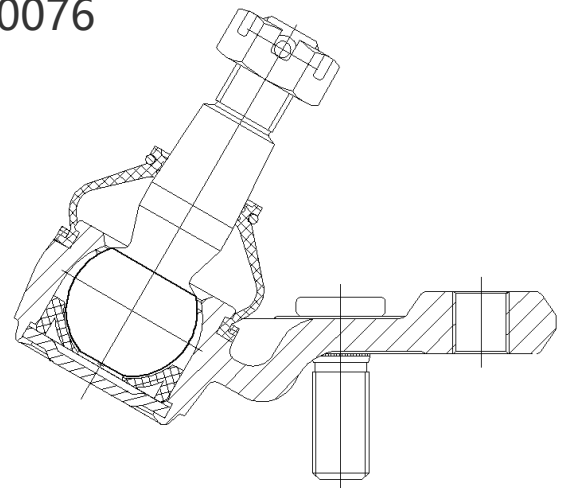

### Improvements

On the premise of ensuring the service performance, the ball diameter is optimized by  $S\phi 25$  changed to  $S\phi 28$ . After the ball diameter is increased, the working stability of the product is improved and the durability is better.

